

# MRT1

SPEC SHEET

## FEATURES

Weather Resistant Rubber Seals

Fully Seam Welded

Strong Key Lockable T-Locks

Full Length Piano Type Hinge



## SPECIFICATIONS

600mm x 420mm x 200mm

Heavy Duty 2mm Aluminium

Includes both left and right toolbox

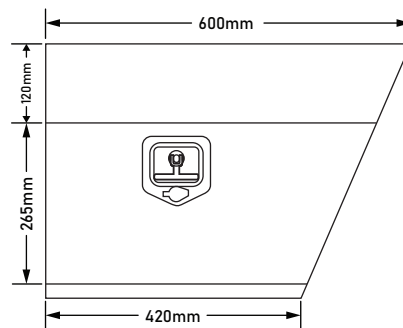

FRONT VIEW

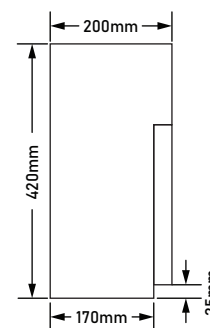

SIDE VIEW

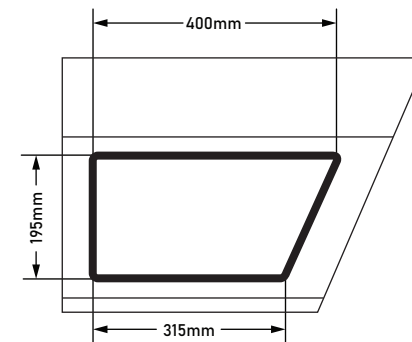

FRONT WITHOUT DOOR