

# PANTRY DXP-B

SPEC SHEET

## FEATURES

- Heavy Duty Aluminium
- Unique Drawer Design for Smooth Operation
- Fingertip Opening
- Push Shut Closing
- Light and Robust
- Finished in Tough Black Textured Powder-coat with Silver Anodised Drawer Fronts
- Bumper Plates on Shelves

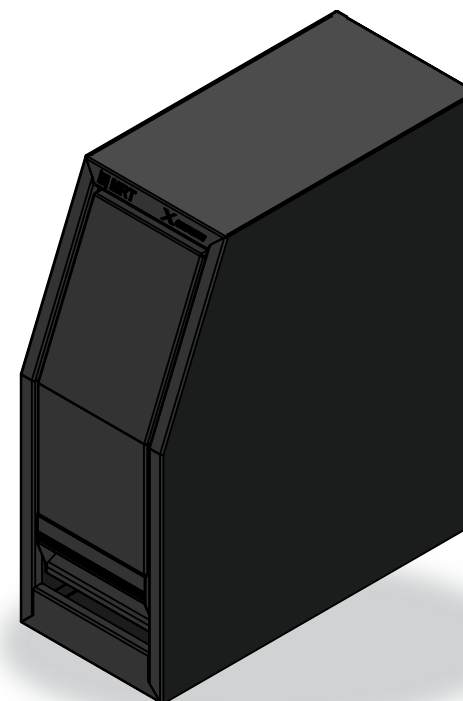

## SPECIFICATIONS

- 250mm x 560mm x 655mm
- 3x Shelves
- Weight: 15.2kg

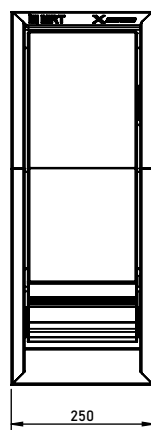

FRONT VIEW

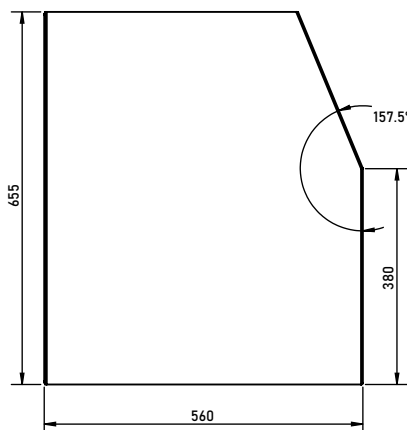

SIDE VIEW (CLOSED)

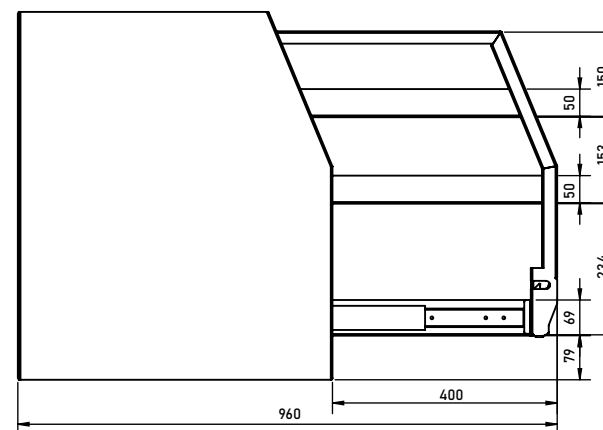

SIDE VIEW (OPENED)

MODEL ID: PANTRY DXP-B